

PRESS RELEASE

SEPTEMBER 2019

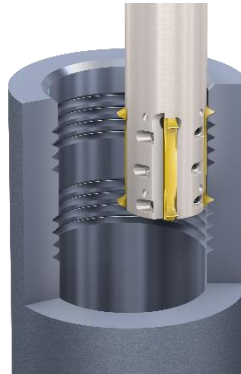

### New from VARGUS: MiTM Offset – Fast Machining for Large Pitches in Deep Holes

*Multi-Flute Indexable Thread Milling with Two Cutting Rows*

September 2019 – At EMO Hannover 2019, **VARGUS Ltd.** is pleased to introduce the innovative, patent pending indexable MiTM Offset line, specially designed to thread mill large pitches in deep holes.

The new MiTM Offset dramatically reduces machining times by offering two cutting rows threading simultaneously.

#### MiTM Offset - Operating Cycle

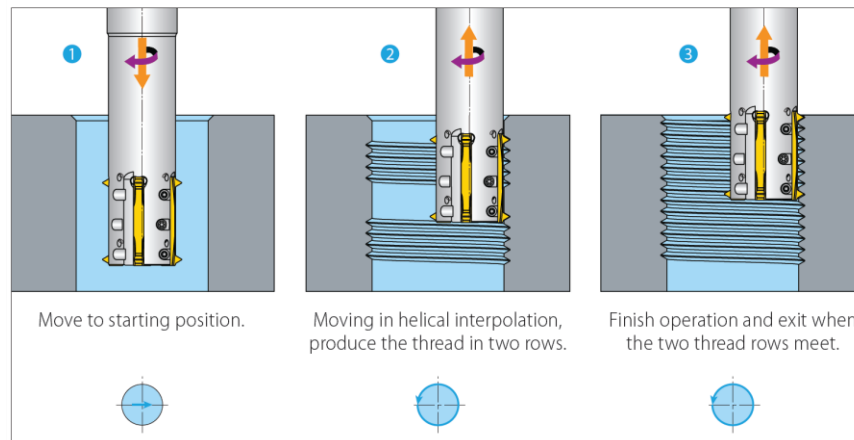

MiTM Offset inserts come in two different sizes - 25mm (MiTM25) & 41mm (MiTM41). Additionally, each insert offers two cutting edges per insert.

Each size is offered with one or two teeth:

- Single tooth inserts are recommended for 2 to 2.5xDo (thread diameter)
- Double tooth inserts are recommended for up to 2xDo (thread diameter)

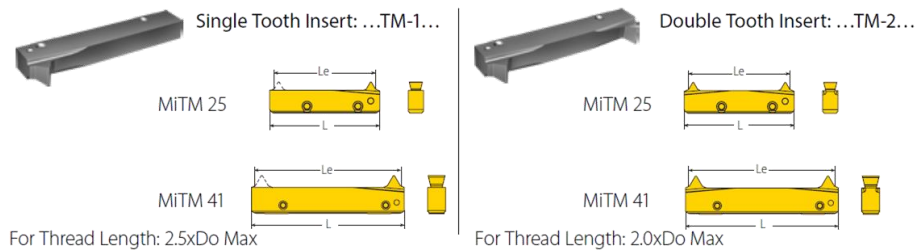

MiTM Offset inserts can be mounted and used with the popular standard MiTM holders to better reduce cutting forces.

MiTM Offset inserts are available in threading standards ISO Metric (Pitches 3.0 to 6.0mm) and American UN (8 to 6 TPI) in the following grades:

- VTX: TiAlN coated carbide grade, ideal for stainless steel.
- VBX: TiCN coated carbide grade, especially suited for steel and general use.

The new MiTM Offset line includes both cylindrical steel holders and shell mill holders. These toolholders offer up to six flutes for greater machining times. Both toolholder types are available with coolant outlets, designed to cool down the cutting corners for longer tool life and deliver better chip evacuation.

MiTM Offset Shell Mill holders can also be used with the standard MiTM inserts for various thread milling applications.

When required, the length of the cylindrical steel holders can be modified and cut for increased stability.

As with the entire MiTM line, all MiTM Offset holders are nickel coated for greater wear resistance and anti-corrosion protection.

The new MiTM Offset line is integrated in the **VARGUS GENius™** software for tool selection and cutting data – ready to meet the most demanding threading requirements.

For more information visit us at EMO Hannover 2019: Hall 3, Stand H 29

**Issued on behalf of VARGUS Ltd.**

David Wolfe, Vice President Sales & Marketing  
 Annie Reuveni, Marketing Communications Manager  
 General Inquiries

[davidw@vargus.com](mailto:davidw@vargus.com)  
[annier@vargus.com](mailto:annier@vargus.com)  
[mrktg@vargus.com](mailto:mrktg@vargus.com)

About VARGUS: *VARGUS Ltd., established in 1960, is the tooling division of the NEUMO Ehrenberg Group, a multinational organization with over 30 companies worldwide. VARGUS Ltd., serving customers in more than 100 countries around the globe, is a leading manufacturer and supplier of quality tooling for threading, turning, milling and grooving applications, as well as hand deburring tools. A customer-focused organization, VARGUS Ltd. is committed to providing innovative products and solutions of the highest quality and excellent value and is renowned for its technical expertise and uncompromising service.*